



产品规格书

PRODUCT SPECIFICATION

BMF150-225W-ACOO管道风机
IN-LINE DUCT FANS
(220V 50Hz)

客户号(Customer): 0000-0000

版本 (Edition): A00

日期 (Date): 2023.08.09

1.0 概述/ Introduction

本规格书主要描述了产品标准、使用环境、技术要求等.

This specification describes the standard、operation environment、and technic requirements of the product.

2.0 产品标准和安规要求/Requirement of production standard and safety regulations

2.1 本产品符合的标准 / The product satisfy requirements

2.1.1 GB12350 《小功率电动机的安全要求》

GB12350 《Safety requirments of small power motors》

2.1.2 JB/T10563 《一般用途离心通风机通用技术条件要求》

JB/T10563 《General technical requirement for general centrifugal fan》

2.1.3 EN60335-1 《家电和类似用途电器的安全要求》

EN60335-1 《Household and similar electrical appliances-safety》

2.2 本产品通过 CCC、CE 认证

The fan has CCC、CE certificate

2.3 本产品全部材料符合RoHS要求

All material accord with RoHS.

3.0 机械要求/ Mechanical requirements

3.1 外形图/Dimension drawing

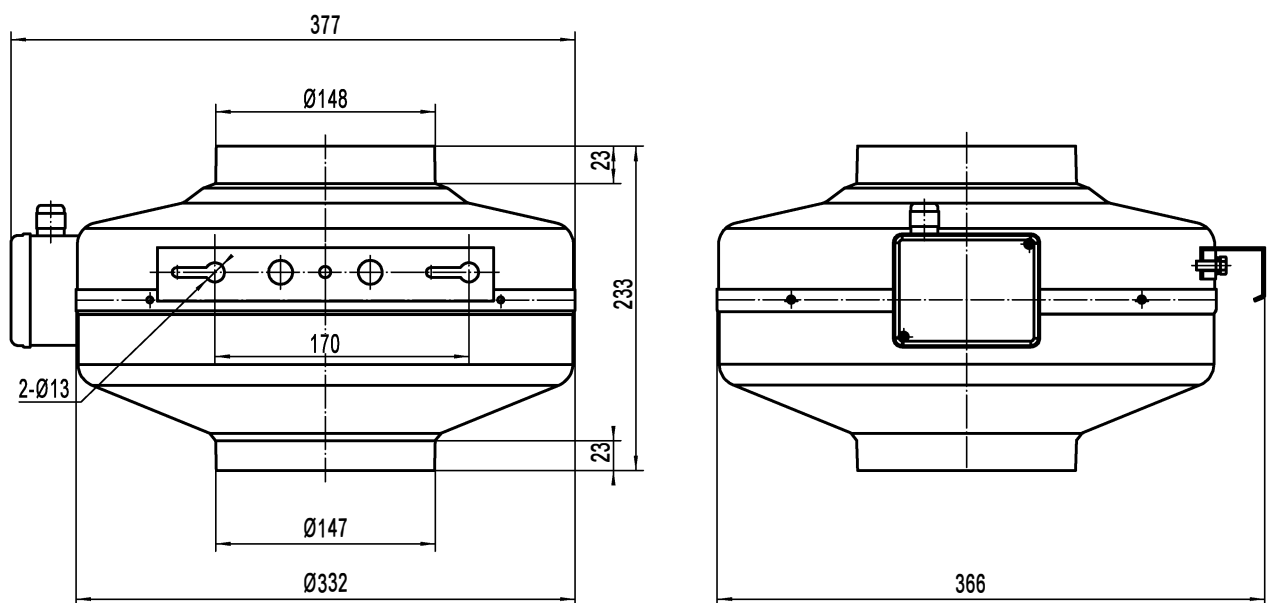

3.2 材质/Material

风轮塑料PA66,转子铸铝

Impeller material: Plastic PA66, Rotor: Aluminum Casting

3.3 电机/Motor

外转子交流电机/ External rotor AC motor

3.4 轴承

免维护滚珠球轴承/ Maintenance free ball bearings

3.5 平衡/ Balancing

风机在额定电压和频率下运转时，每个端面动平衡精度不低于G6.3，符合标准JB/T9101。

At the rated voltage and frequency,,the residual unbalance of the fan is not less than G6.3 (balancing precision grade) in each plane,according with JB/T9101。

3.6 振动/Vibration of the fan

风机振动速度有效值按照JB/T8689标准规定。

Vibration speed virtual value of fans accord with JB/T8689。

3.7 跳动/ Runout of impeller

风轮轴向、径向跳动 $\leq 0.8\text{mm}$ 。

Runout of impeller in axial and radial direction $\leq 0.8\text{mm}$ 。

3.8 寿命/Life time

风机寿命估算值L10:30000小时，（在额定电压、环境温度为40℃、风机全速运转时）

Fan life expectanceL10:30000 hours, determined when at nominal supply voltage,running at full speed, environment temperature of 40 °C。

4.0 风机性能/Fan performance

4.1 性能参数/Performance data

	Voltage	Frequency	Current	Input Power	Speed	Capacitor	Air Flow	Noise	Operating Temperature	Curve No.	Approvals
Model No.	V	Hz	A	W	rpm	μF	$\text{m}^3/\text{h.CFM}$	dB(A)	Min / Max($^{\circ}\text{C}$)	#	
G2E150-225W-AC00	220	50	0.45	95	2550	2.5	560 / 329	67	-30 / +60	①	CCC ,CE,RoHS

4.2 特性曲线/Performance curve

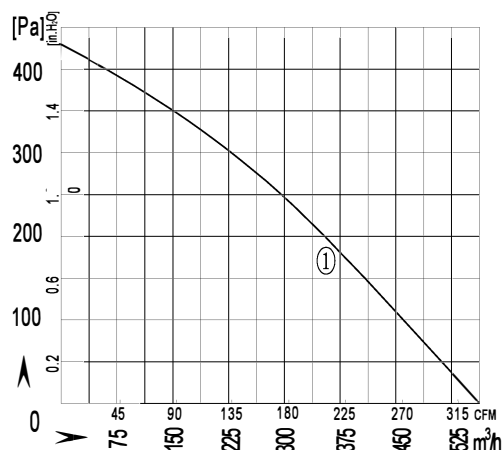

5.0 电气性能/Electrical performance

5.1 铭牌/Label

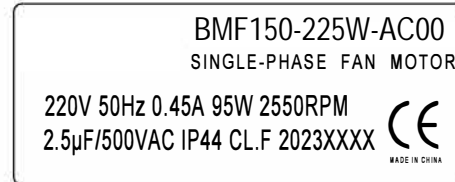

5.2 接线图/Wiring diagram

注：除客户要求带接线图外其余不带

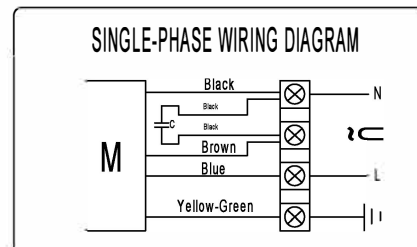
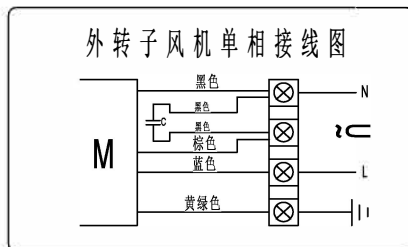

5.3 电压范围/Voltage range

风机设计的额定运行电压为220V，可运行的电压范围是198~242V，

The fan is designed to operate at a nominal voltage of 220V but can be operated in the AC supply voltage range of 198 to 242 V.

5.4 防护等级/Type of protection

风机的防护等级为IP44。

Type of protection is IP44.

5.5 绝缘等级：F

Insulation Class: F

6.0 质量要求/Quality requests

质量要求符合ISO9001:2000 / Quality requests accord with ISO9001:2000

质量要求符合企业标准 / Quality requests accord with AFL standard

7.0 使用和存储环境/ Operating and storing environment requirements

7.1 使用环境/ Operating environment requirements

使用温度范围/Operating temperatures from: $-30^{\circ}\text{C}\sim+60^{\circ}\text{C}$

使用湿度范围/Operating humidity from: $0\%\sim95\% \text{RH}$

海拔高度/The altitude: $\leq 1000\text{m}$

7.2 贮存环境/Storing environment requirements

贮存温度范围: $-40^{\circ}\text{C}\sim+80^{\circ}\text{C}$, 贮存湿度范围: $0\%\sim95\% \text{RH}$ 。

Storing temperatures from -40°C to $+80^{\circ}\text{C}$; Storing humidity from 0% to 95% RH。

8.0 包装和标识/ Packaging and marks

8.1 包装/Packaging

泡沫盒包装/Bubble chamber packaging

8.2 标识/Marks

制造商名称、产品型号、重量、尺寸等

Markings: Name of manufacturer, type of fan, date of manufacture, weight, Size etc.

9.0 附件/Other requirements on accessory

9.1 电容/Capacitor

■带/Yes, □不带/No, □根据销售订单配备/For Salers' request;

9.2 连接件要求/Annectent parts

端子/terminal(□有/Yes、■没有//No)